

CLUB CAR 2000

REAR SEAT KIT

RS1007 and RS1008

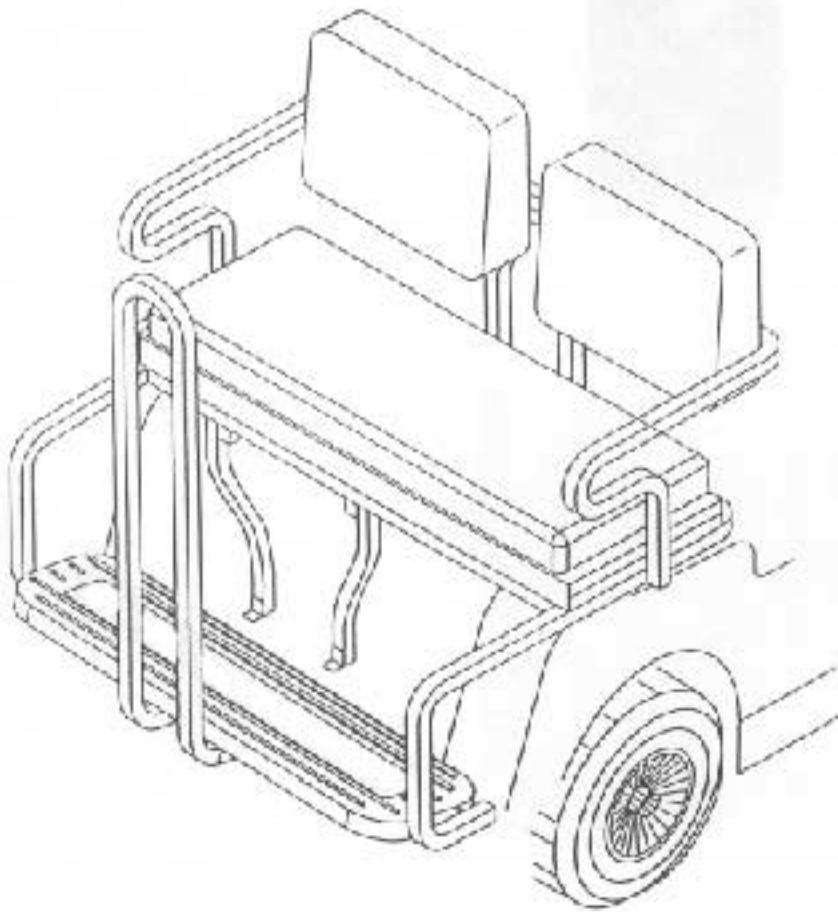

HARDWARE INCLUDED:

- (4) 5/16-18 NUTS
- (4) 2-1/4" x 5/16-18 BOLTS
- (8) 7/8" FLAT WASHERS
- (2) 1" SPACERS

- (4) 1/8" "L" BRACKETS
- (2) 1" x 1/4-20 BOLTS
- (6) 1-1/2" x 1/4-20 BOLTS
- (2) 2-1/2" x 1/4-20 BOLTS
- (4) 3" x 1/4-20 BOLTS
- (2) 3-1/2" x 1/4-20 BOLTS
- (2) 3" x 1/4-20 CARRIAGE BOLTS
- (4) 4" x 1/4-20 BOLTS
- (32) 1/4-20 NUTS
- (58) FLAT WASHERS

NOTE: Some hardware is specific for certain seat kits. You may find extra hardware remaining after your installation.

PLEASE CONTACT SUPPLIER IF ANY HARDWARE IS MISSING.



TOOLS REQUIRED:

- 17/64" DRILL BIT/DRILL
- 7/16" SOCKET
- 7/16" WRENCH

STEP 1: MOUNT FRONT SUPPORTS

PAGE 2 OF 4

FOLLOW SEQUENCE BELOW; *FINGER TIGHTEN ONLY UNTIL UNIT IS FULLY ASSEMBLED.*

- 1) REMOVE SEAT BACK AND MOUNTINGS.
- 2) BOLT CENTER "U" FRAME TO FACTORY MOUNTING HOLES BEHIND SEAT BOTTOM.
- 3) MOUNT FRONT OF CENTER SUPPORTS AS SHOWN.
- 4) REMOUNT SEAT BACK

NOTE: BOLTS REQUIRE (2) 3/4 WASHERS AND (1) 1/4-20 NUT
BOLTS MARKED ** REQUIRE (2) 7/8 WASHERS AND (1) 5/16-18 NUT.

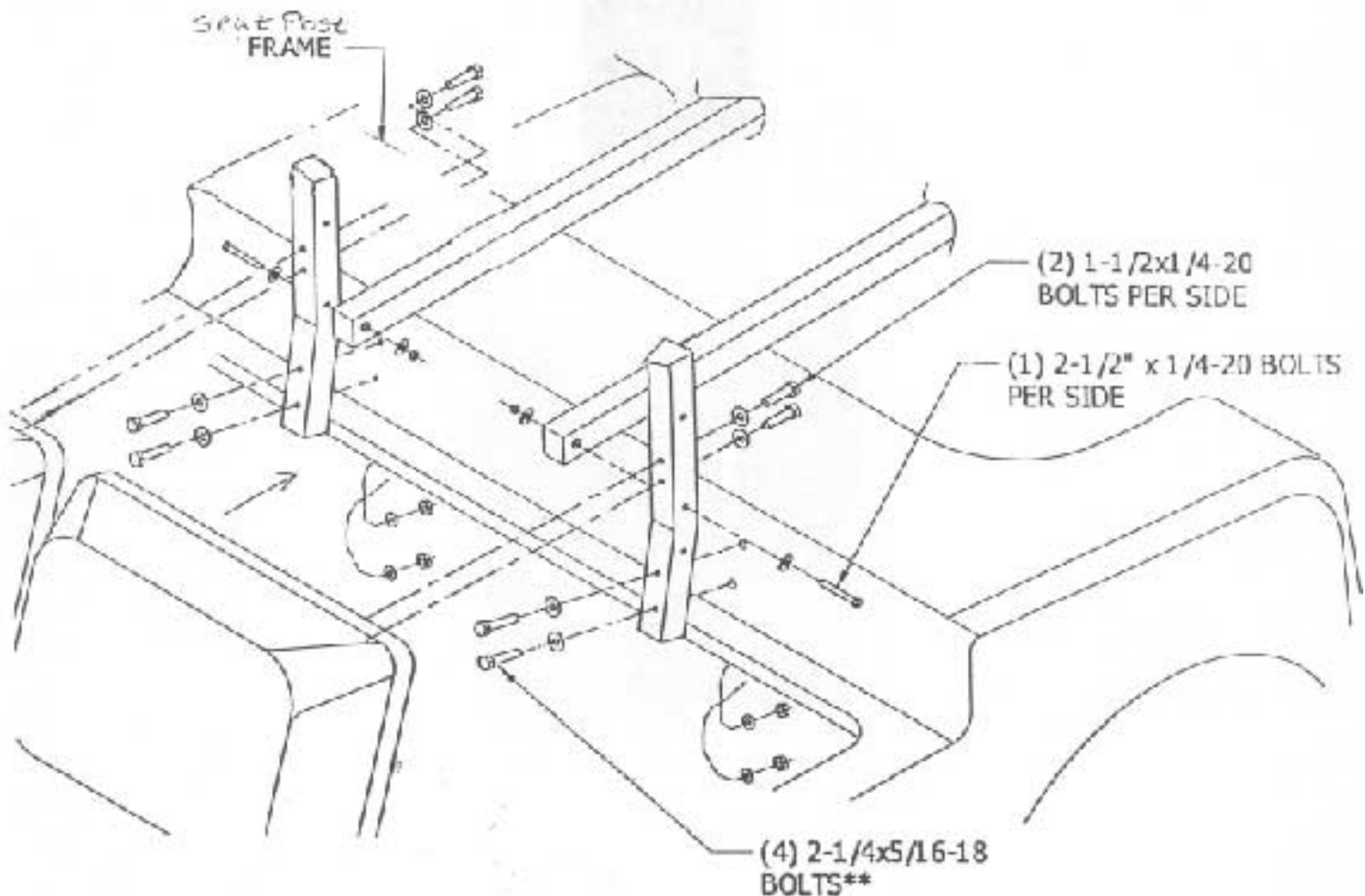

STEP 2: FINAL ASSEMBLY

PAGE 3 OF 4

FOLLOW SEQUENCE BELOW; *FINGER TIGHTEN ONLY UNTIL UNIT IS FULLY ASSEMBLED, THEN TIGHTEN COMPLETELY.*

- 1) REMOVE BUMPER.
- 2) MOUNT 1/8" "L" BRACKETS TO LOWER CENTER SUPPORT TUBES (FACING AS SHOWN.)
- 3) BOLT CENTER SUPPORTS TO BAGWELL FLOOR USING EXISTING HOLES.
- 4) USING STUDS ON UNDERSIDE OF FOOTREST, MOUNT ASSEMBLY TO CAR WITH SUPPORT TUBES BELOW CAR AS SHOWN.

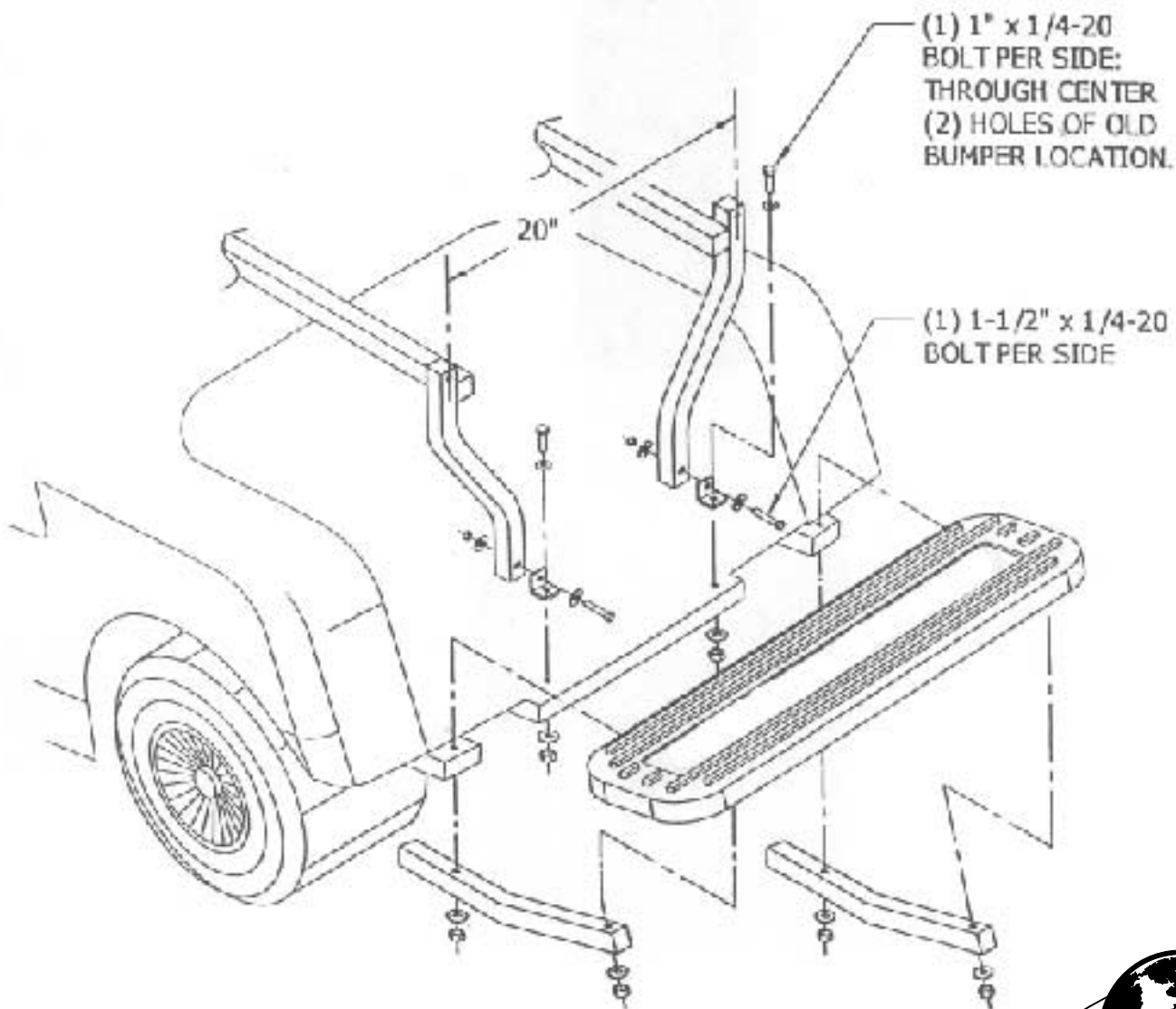

FOLLOW SEQUENCE BELOW; *FINGER TIGHTEN ONLY UNTIL UNIT IS FULLY ASSEMBLED, THEN TIGHTEN COMPLETELY.*

- 7) ATTACH SEAT BACK CUSHIONS TO SEAT ASSEMBLY. MOUNT SEAT ASSEMBLY ONTO CENTER SUPPORTS; BOLT ON "L" BRACKETS AS SHOWN; STANDARD SEAT REQUIRES ONE PLACEMENT / "2 IN 1" AND "3-IN-1" COMBO VERSIONS REQUIRE THE OTHER PLACEMENT.
NOTE: CROSS BRACE IS ALSO REQUIRED WHEN INSTALLING "3-IN-1" COMBO SEAT KITS.
- 8) MOUNT SIDE TUBES INTO SEAT ASSEMBLY AND ONTO THE STEP. USE SPACERS WITH "COMBO" KITS.
- 9) MOUNT OPTIONAL CENTER HANDLE, (REQUIRED WITH "2 IN 1" AND "3 IN 1" COMBO KITS. IF HANDLE IS NOT USED, IT IS RECOMENDED TO CUT OFF EXTENDED STUDS BELOW STEP.

